

C. A. JOHNSON.
SCREW CUTTING DIE.

No. 464,568.

Patented Dec. 8, 1891.

Fig. 1.

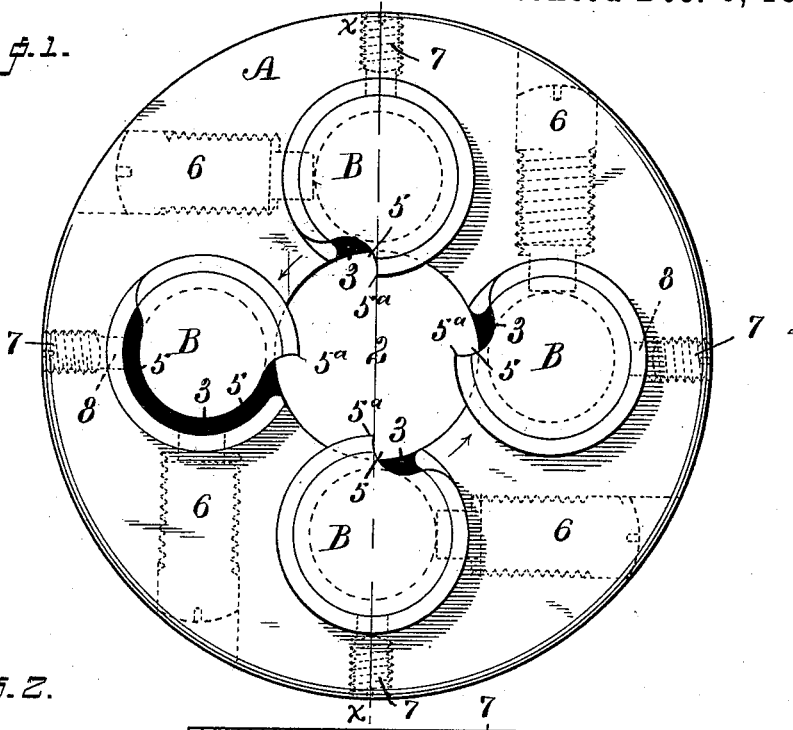
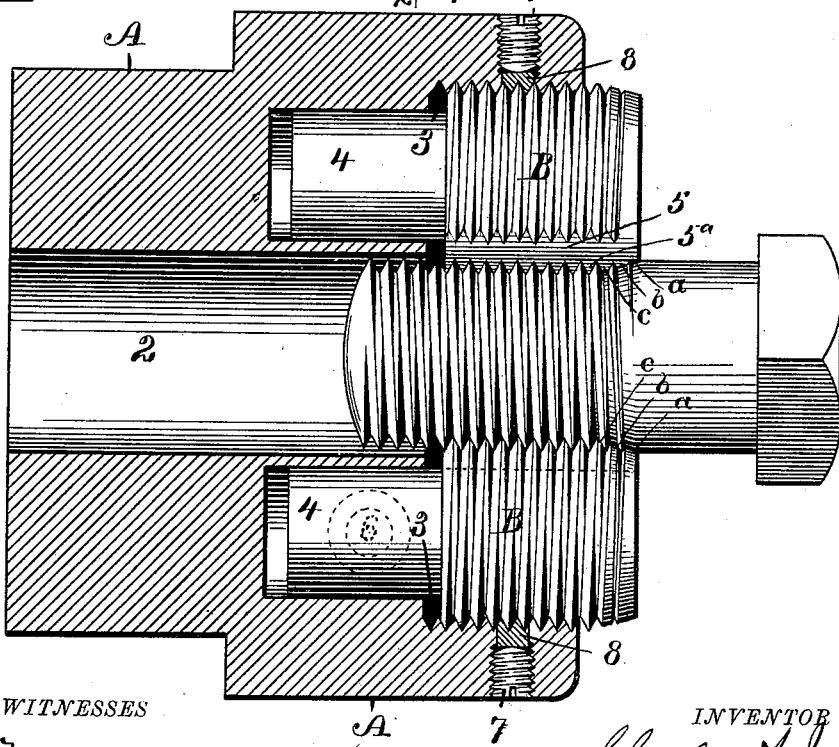

Fig. 2.



WITNESSES

C. M. Newman,
Arley S. Munson.

INVENTOR

Charles A. Johnson
By J. M. Wooster
Att'y.

C. A. JOHNSON.
SCREW CUTTING DIE.

No. 464,568.

Patented Dec. 8, 1891.

Fig. 3.

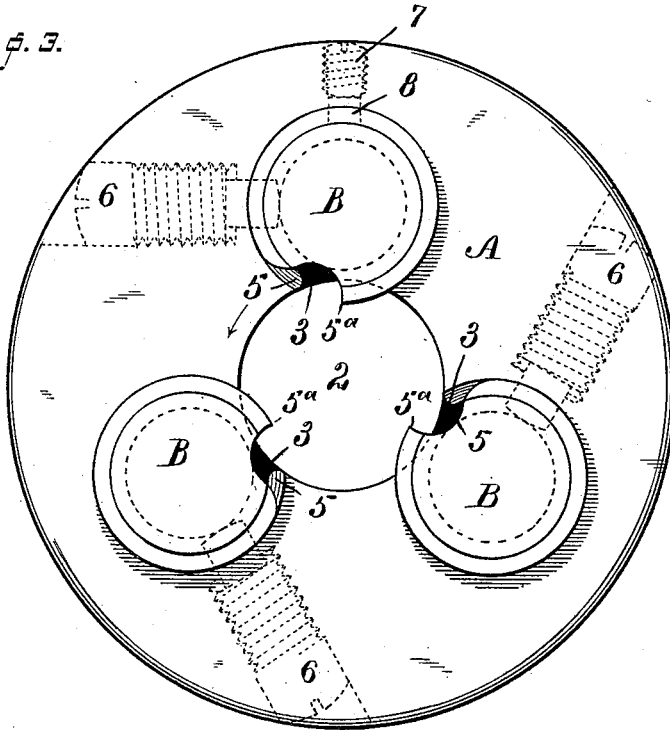

Fig. 4.

B

4

3^a c b a

Fig. 5.

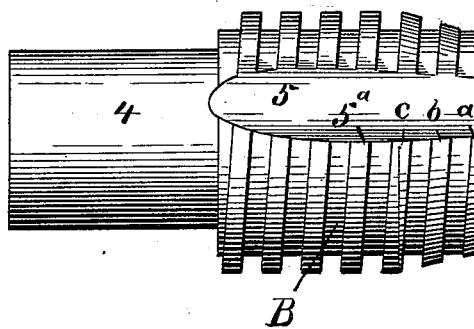

WITNESSES

C. M. Newman,
Arley J. Munson

INVENTOR

Charles A. Johnson
By A. W. Worcester
att.

UNITED STATES PATENT OFFICE.

CHARLES A. JOHNSON, OF HARTFORD, CONNECTICUT.

SCREW-CUTTING DIE.

SPECIFICATION forming part of Letters Patent No. 464,568, dated December 8, 1891.

Application filed February 2, 1891. Serial No. 379,385. (No model.)

To all whom it may concern:

Be it known that I, CHARLES A. JOHNSON, a subject of the King of Sweden, residing at Hartford, in the county of Hartford and State of Connecticut, have invented certain new and useful Improvements in Dies for Cutting Threads; and I do hereby declare the following to be a full, clear, and exact description of the invention, such as will enable others skilled in the art to which it appertains to make and use the same.

My invention has for its object to simplify, cheapen, and to greatly improve the construction, operation, and adjustment of dies for cutting threads and to increase their durability to such an extent that each die shall be capable of having twelve to fifteen times the amount of stock ground away that can be spared from ordinary concave dies, while at the same time the construction shall be such as to prevent wearing away of the surface of the threads, so that after each grinding a die will do just as close work as an entirely new one, thus doing away with the necessity for lathe-finishing in the finer grades of work.

With these ends in view I have devised the novel cylindrical die which I will now describe, referring by numerals to the accompanying drawings, forming part of this specification, in which—

Figure 1 is a front elevation of a die-head, showing four of my novel dies in operative position; Fig. 2, a section on the line $x x$ in Fig. 1, showing the manner in which a bolt or rod is threaded; Fig. 3, a front elevation corresponding with Fig. 1, showing the use of three dies instead of four; and Figs. 4 and 5 are views of dies detached, showing different styles of threads.

A denotes a die-head, which may be of any ordinary or preferred construction, and is provided with the usual central recess 2, which receives the bolt or rod to be threaded. Outside of recess 2 in the face of the head are recesses 3, adapted to receive the dies, which are inserted from the front, these recesses opening into recess 2, as clearly shown in Figs. 1 and 3.

B denotes my novel dies, which are cylindrical in form, are threaded upon their peripheries, and may or may not be provided with shanks 4, as shown in the drawings. It will be noticed (see Fig. 2) that the recesses 3 are provided with female threads, which are engaged by the threads of the dies, and, furthermore, that the inner ends of said recesses are reduced in diameter but are not threaded. The reduced inner ends of the recesses are to receive the shanks of the dies which I ordinarily use, so as to give the greatest possible rigidity and strength. Any convenient number of dies may be used and the threads may be of any required shape or style, the first thread (denoted by a) being the lowest and cutting the first chip; the second (denoted by b) being higher and cutting another chip; the third (denoted by c) being still higher and cutting nearly to the depth of the perfect thread, and the fourth and succeeding threads being full height.

5 denotes a cut in the die, which is made transversely to the threads and deeper than the threads. The operative side of this cut—*i. e.*, the cutting-edge—which is abrupt, is denoted by 5^a . The line of the cutting-edge may be parallel or inclined to a line parallel with the axis of the die.

In practice I ordinarily form the line of the cutting-edge so that after passing the third and fourth threads going backward, each succeeding thread projects forward slightly in advance of the others, the object being to make the rear threads of the dies, which simply act as holding-threads, take hold upon the threaded portion of the bolt or rod slightly in advance of the cutting-threads at each revolution. I thus insure that the bolt or rod shall not have the slightest endwise movement, and render it wholly impossible for the threads of the dies to remove metal from the sides of the threads upon the bolt or rod.

The dies are sharpened or ground down by grinding off the face of the cutting-edge of the threads—that is to say, by grinding off the ends of the threads. This will be clearly understood from the left die in Fig. 1, which shows a die that has been in use for a long time and which has been sharpened or ground down until more than one-half of the threaded

portion of the die has been ground away. This process of grinding down or sharpening can be continued until from two-thirds to three-fourths of the surface of the die has
 5 been ground away in the manner indicated at the left in Fig. 1. In other words, the ends of the threads may be ground away as long as there is metal enough left in the threads to enable the dies to do their work and to be held
 10 in place in the head.

It will be apparent that the essential difference between my novel dies and dies as heretofore constructed is that I employ convex cutting-threads instead of concave cutting-threads and do all the work with the
 15 ends of the threads, the threads themselves curving away from the rod or bolt upon which they are acting, thus avoiding all wear upon the sides of the threads of the dies and enabling dies long in use to do just as accurate
 20 work as new ones.

It will be apparent that in using a series of dies of this class they must be set so as to act successively upon a rod or bolt. Suppose, for
 25 instance, that four dies are used in the series, as in Fig. 1. It is obvious that the second die must be so set as to engage a bolt or rod a quarter of a turn after the first die, the third die to engage a half-turn after the first die,
 30 and the fourth die to engage three-quarters of a turn after the first die. This arrangement, it is thought, will be clearly understood from Fig. 2, in which the top die may be considered the first die and the lower die as the
 35 third die. If three dies are employed in the series, the second die would of course engage a third of a turn after the first die and the third die two-thirds of a turn after the first die. In practice I ordinarily accomplish this
 40 result by threading recesses 3 in the head in such a manner that the threads run out at the quarters of the circle.

It will be noticed in Fig. 2 that the dies are shown as projecting considerable distance beyond the face of the head. In practice I usually leave about one-third of the threaded
 45 portion of the die projecting beyond the face of the head. This serves two important purposes, in that it enables the operator without difficulty to place oil at the exact place where
 50 the work is being done, and, second, it insures that all of the chips shall drop outside of the head.

The dies may or may not be threaded to correspond with recesses 3. If they are threaded to correspond with said recesses—that is, the threads following each other to act at quarter-turns—all of the dies will in use project
 55 the same distance from the face of the head. If the dies are all cut alike and not to correspond with the recesses, they can easily be adjusted, but will project different distances from the face of the head.

In placing the dies in the head or in adjusting them they are simply turned to position

by any suitable tool, and when in position are locked against turning by set-screws 6. In Fig. 2 I have shown these set-screws as engaging the shanks of the dies. It is of course wholly immaterial whether they engage the
 70 shanks of the dies or the operative portion thereof. 7 denotes other set-screws, which may or may not be used. These screws are placed radially in the head and act to force the dies directly inward toward the center of
 75 the opening. In practice blocks 8 of soft metal are placed between the inner ends of the set-screws and the threads of the dies. These screws are only used for purposes of adjustment. Should it be required at any
 80 time to cut the threads slightly deeper or less deep, this result can be accomplished by tightening or loosening set-screws 7.

Having thus described my invention, I claim—

1. A die for cutting male threads, having peripheral threads, the outer of which is lowest, the next slightly higher, and so continuing until the full height of the threads is reached, after which the threads are of uniform height, and a cut made transversely to said threads to form an abrupt cutting-edge the face only of which is cut away in sharpening, so that the cutting-edges retain their full height and can be used until the greater
 90 portion of the periphery has been ground away.

2. A die for cutting male threads, having peripheral threads and a cut made transversely thereto to form a cutting-edge, the operative face of said cutting-edge inclining inward from the front toward the back, so that the rear threads will engage the article to be threaded prior to the threads by which the cutting is done.

3. The combination, with a die-head having a central recess to receive the article to be threaded and other recesses outside of said central recess, of cylindrical dies lying in the outer recesses, substantially as described.

4. The combination, with a die-head having a central recess to receive the article to be threaded and other recesses outside of said central recess, of cylindrical dies lying in the outer recesses, set-screws for locking the dies
 115 against turning, and other set-screws for adjustment.

5. The combination, with a die-head having a central recess to receive the article to be threaded and a threaded recess outside of said central recess and opening into said central recess, of a cylindrical die having threads upon its periphery to engage the threads of the recess and a cut made transversely to said threads to form an abrupt cutting-edge which
 125 extends into the central recess, substantially as described.

6. The combination, with a die-head having recesses 3, the outer ends of which are threaded, the inner ends being unthreaded, of

70

75

80

85

90

95

100

105

110

115

120

125

130

dies having cutting-threads which engage the threaded portions of the recesses and shanks engaging the unthreaded portions thereof, substantially as described.

5 7. The combination, with a die-head having threaded recesses 3, the threads of said recesses following each other in parts of turns, substantially as described, of cylindrical dies

having cutting-threads which engage said recesses.

In testimony whereof I affix my signature in presence of two witnesses.

CHARLES A. JOHNSON.

Witnesses:

A. M. WOOSTER,
ARLEY I. MUNSON.

10